



CONTRACTOR LINE

# MOBISCREEN MS 12 Z

TECHNICAL SPECIFICATIONS

■ TRACK-MOUNTED SCREENING PLANT



Side view MS 12 Z-AD transport position

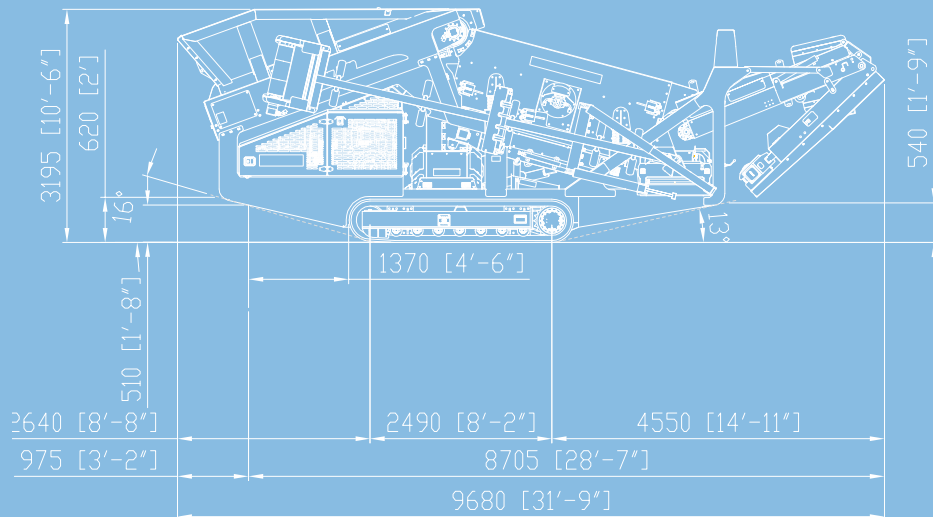

TECHNICAL SPECIFICATIONS MS 12 Z-AD

<b>Feeding unit</b>		<b>Belt conveyor medium fractions</b>	
Feed capacity up to approx. (t/h)	300	Width x length (mm)	650 x 7030
Feed size max. (mm)	250 x 250	Discharge height approx. (mm)	3500
Feed height (mm)	2840 (2395)	<b>Belt conveyor oversize fractions</b>	
Hopper capacity (m³)	4	Width x length (mm)	1050 x 4670
<b>Belt conveyor feeder</b>		Discharge height approx. (mm)	3380
Width x length (mm)	1220 x 3195	<b>Crawler chassis</b>	
Discharge height approx. (mm)	–	Type	D2
<b>Screening unit</b>		<b>Diesel-hydraulic drive</b>	
Type	double-deck vibration screen	Engine power (kW)	63
Width x length (mm)	1220 x 2745	<b>Transport</b>	
<b>Belt conveyor underflow material</b>		Transport height approx. (mm)	3200
Width x length (mm)	1050 x 2215	Transport length approx. (mm)	9680
Discharge height approx. (mm)	–	Transport width approx. (mm)	2500
<b>Belt conveyor fines fractions</b>		Transport weight approx. (kg)	15400
Width x length (mm)	650 x 7030		
Discharge height approx. (mm)	3500		