

CONTRACTOR LINE

MOBISCREEN MS 13 Z

TECHNICAL SPECIFICATIONS

■ TRACK-MOUNTED SCREENING PLANT



Side view MS 13 Z-AD transport position

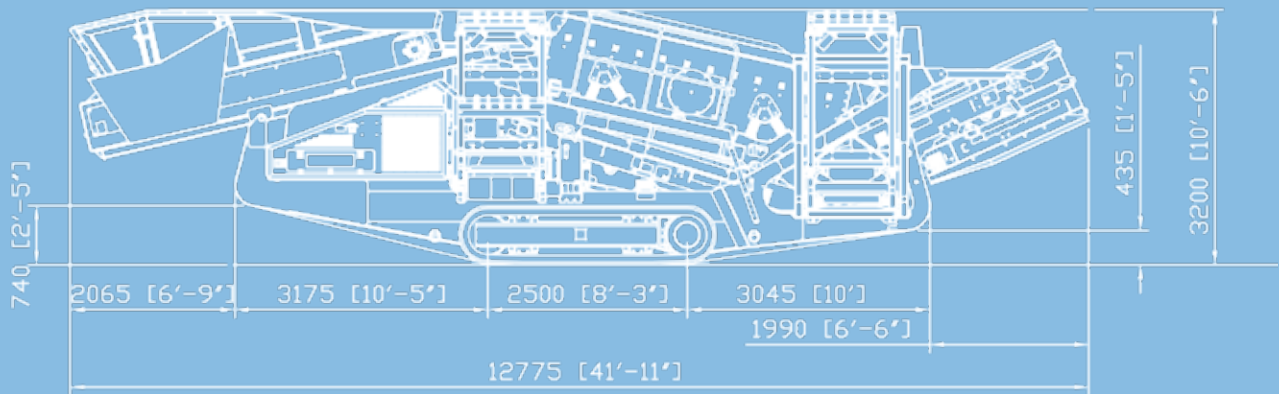

TECHNICAL SPECIFICATIONS MS 13 Z-AD

Feeding unit		Belt conveyor medium fractions	
Feed capacity up to approx. (t/h)	350	Width x length (mm)	800 x 7300
Feed size max. (mm)	250 x 250	Discharge height approx. (mm)	2600 - 3600
Feed height (mm)	3395 (2920)	Belt conveyor oversize fractions	
Hopper capacity (m³)	6	Width x length (mm)	1200 x 4600
Belt conveyor feeder		Discharge height approx. (mm)	3100 - 3400
Width x length (mm)	1200 x 3900	Crawler chassis	
Discharge height approx. (mm)	–	Type	D3
Screening unit		Diesel-hydraulic drive	
Type	double-deck vibration screen	Engine power (kW)	75
Width x length (mm)	1370 x 3660	Transport	
Belt conveyor underflow material		Transport height approx. (mm)	3200
Width x length (mm)	1050 x 3300	Transport length approx. (mm)	12780
Discharge height approx. (mm)	–	Transport width approx. (mm)	2500
Belt conveyor fines fractions		Transport weight approx. (kg)	23000
Width x length (mm)	800 x 6800		
Discharge height approx. (mm)	3200 - 3600		