



CONTRACTOR LINE

MOBISCREEN MS 16 D

TECHNICAL SPECIFICATIONS

■ TRACK-MOUNTED SCREENING PLANT



Side view MS 16 D transport position

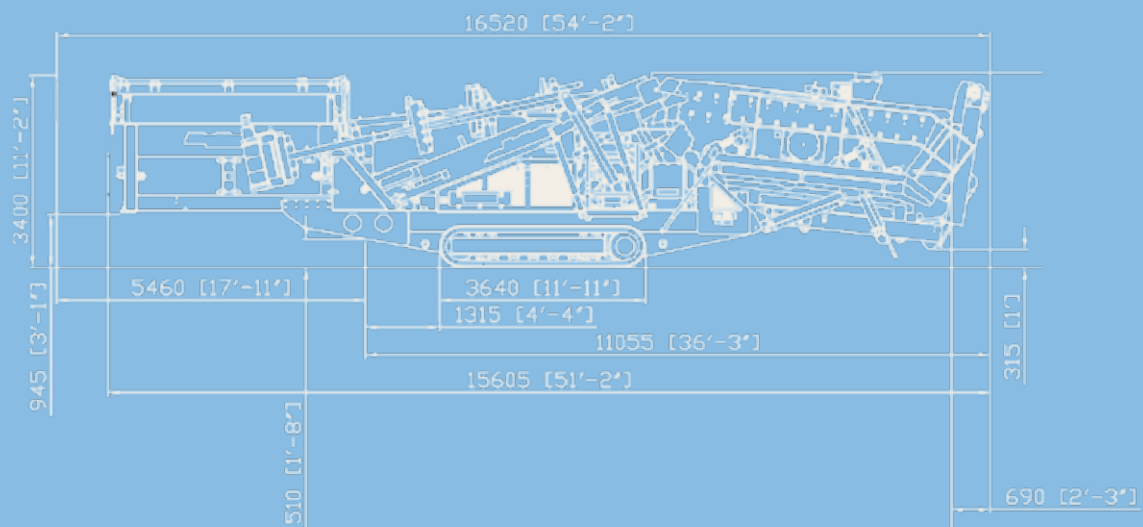

TECHNICAL SPECIFICATIONS MS 16 D

Feeding unit		Belt conveyor medium fractions (lower deck)	
Feed capacity up to approx. (t/h)	350	Width x length (mm)	650 x 9100
Feed size max. (mm)	150 x 150	Discharge height approx. (mm)	4600
Feed height (mm)	3635	Belt conveyor medium fractions (middle deck)	
Hopper capacity (m ³)	8	Width x length (mm)	650 x 9100
Belt conveyor feeder		Discharge height approx. (mm)	4600
Width x length (mm)	1200 x 3500	Belt conveyor oversize fractions	
Discharge height approx. (mm)	–	Width x length (mm)	650 x 1800
Feeding belt conveyor screen		Discharge height approx. (mm)	–
Width x length (mm)	1050 x 9600	Belt conveyor oversize fractions	
Discharge height approx. (mm)	–	Width x length (mm)	500 x 8500
Screening unit		Discharge height approx. (mm)	4700
Type	triple-deck vibration screen	Crawler chassis	
Width x length (mm)	1520 x 4270	Type	D3
Belt conveyor fines fractions		Diesel-hydraulic drive	
Width x length (mm)	1200 x 6300	Engine power (kW)	75
Discharge height approx. (mm)	3900	Transport	
		Transport height approx. (mm)	3450
		Transport length approx. (mm)	15610
		Transport width approx. (mm)	3000
		Transport weight approx. (kg)	29000