



CONTRACTOR LINE

MOBISCREEN MS 19 D

TECHNICAL SPECIFICATIONS

■ TRACK-MOUNTED SCREENING PLANT



Side view MS 19 D transport position

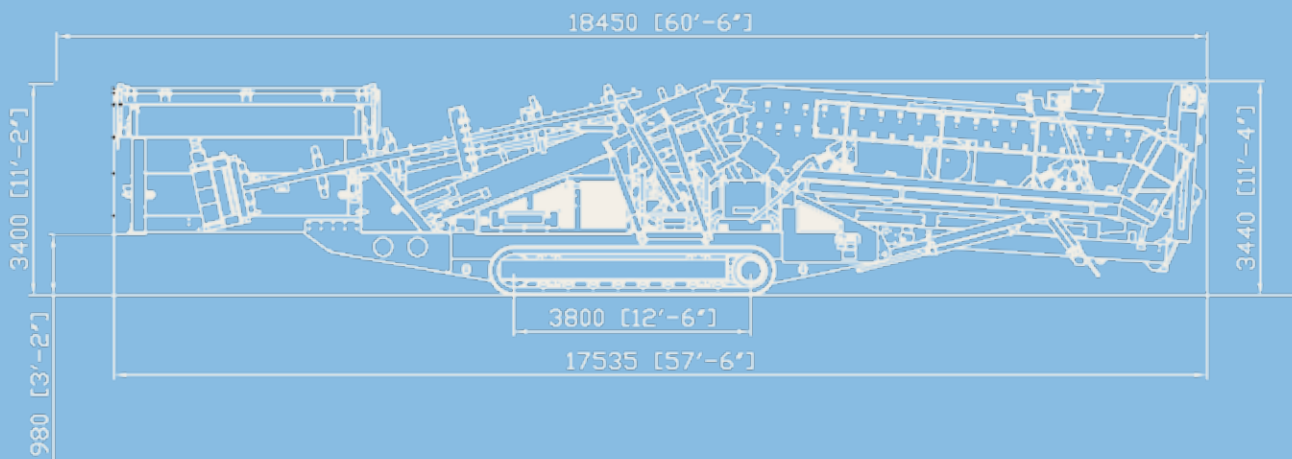

TECHNICAL SPECIFICATIONS MS 19 D

Feeding unit		Belt conveyor medium fractions (lower deck)	
Feed capacity up to approx. (t/h)	500	Width x length (mm)	800 x 10300
Feed size max. (mm)	150 x 150	Discharge height approx. (mm)	5100
Feed height (mm)	3635	Belt conveyor medium fractions (middle deck)	
Hopper capacity (m ³)	8	Width x length (mm)	800 x 10300
Belt conveyor feeder		Discharge height approx. (mm)	5100
Width x length (mm)	1200 x 3500	Belt conveyor oversize fractions	
Discharge height approx. (mm)	–	Width x length (mm)	650 x 1800
Feeding belt conveyor screen		Discharge height approx. (mm)	–
Width x length (mm)	1050 x 11800	Belt conveyor oversize fractions	
Discharge height approx. (mm)	–	Width x length (mm)	500 x 8500
Screening unit		Discharge height approx. (mm)	4700
Type	triple-deck vibration screen	Crawler chassis	
Width x length (mm)	1520 x 6100	Type	D4
Belt conveyor fine fractions		Diesel-hydraulic drive	
Width x length (mm)	1200 x 8000	Engine power (kW)	93
Discharge height approx. (mm)	4600	Transport	
		Transport height approx. (mm)	3450
		Transport length approx. (mm)	17600
		Transport width approx. (mm)	3060
		Transport weight approx. (kg)	36500