



QUARRY LINE

# MOBISCREEN MS 23 D

TECHNICAL SPECIFICATIONS

■ TRACK-MOUNTED SCREENING PLANT



Side view MS 23 D

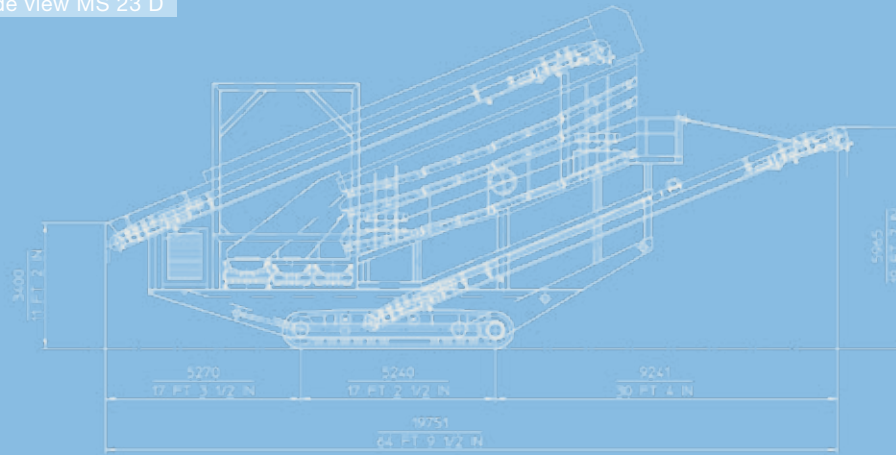

TECHNICAL SPECIFICATIONS MS 23 D

<b>Feeding unit</b>		<b>Belt conveyor screen overflow (middle deck)</b>	
Feed capacity up to approx. (t/h)	800	Width x length (mm)	800 x 3800
Feed size max. (mm)	200 x 200	<b>Belt conveyor discharge screen overflow (middle deck)</b>	
Feed height (mm)	3400	Width x length (mm)	800 x 10000
Hopper capacity (m³)	–	Discharge height approx. (mm)	4390
<b>Belt conveyor feeder</b>		<b>Belt conveyor oversize grain</b>	
Width x length (mm)	1800 x 14000	Width x length (mm)	1000 x 3800
Discharge height approx. (mm)	–	<b>Belt conveyor oversize grain</b>	
<b>Screening unit</b>		Width x length (mm)	1000 x 10000
Type	double-deck vibration screen	Discharge height approx. (mm)	4390
Width x length (mm)	2300 x 8000	<b>Crawler chassis</b>	
<b>Belt conveyor screen underflow</b>		Type	D7
Width x length (mm)	1800 x 14000	<b>Diesel-electric drive</b>	
Discharge height approx. (mm)	5965	Engine power (kW)	225
<b>Belt conveyor screen overflow (lower deck)</b>		Generator (kVA)	250
Width x length (mm)	800 x 3800	<b>Weight</b>	
Discharge height approx. (mm)	–	Operating weight approx. (kg)	85000
<b>Belt conveyor discharge screen overflow (lower deck)</b>		Machine dismantled for transport	
Width x length (mm)	800 x 10000		
Discharge height approx. (mm)	4390		